

## **Series ATP Electric Chemical Injection Pump Operating Manual**



**CheckPoint Headquarters**  
21356 Marion Lane  
Mandeville, Louisiana 70471  
United States of America  
+1 (504) 340-0770

**CheckPoint UK**  
C2 Lombard Centre  
Kirkhill Place, Kirkhill Industrial Estate  
Dyce, Aberdeen AB21 0GU Scotland  
+44 (0)1224 775205

**CP Pumps & Systems FZE**  
Unit AA08, LIU 10  
Jebel Ali South | P.O. Box 262131  
Dubai | UAE  
+971 (4) 8806278

## TABLE OF CONTENTS

<b>1.</b>	<b>SYSTEM REQUIREMENTS</b>	<b>3</b>
1.1	Inspection.....	3
1.2	Storage.....	3
1.3	Unpacking.....	3
1.4	Safety.....	3
1.5	Location.....	3
1.6	Typical Installation Schematic.....	4
1.7	Connect chemical and process lines to checks.....	4
<b>2.</b>	<b>MOTOR INSTALLATION</b>	<b>5</b>
2.1	Motor Requirements.....	5
<b>3.</b>	<b>INJECTION HEAD ASSEMBLY</b>	<b>6</b>
3.1	Adding an Injection Head.....	7
<b>4.</b>	<b>STROKE LENGTH ADJUSTMENT</b>	<b>9</b>
4.1	Adjusting the stroke length.....	9
<b>5.</b>	<b>OPERATION</b>	<b>10</b>
5.1	Initial Startup.....	11
<b>6.</b>	<b>TROUBLESHOOTING</b>	<b>11</b>
6.1	Pump does not stroke.....	11
6.2	Drive is excessively noisy.....	11
6.3	Miscellaneous.....	12

## **1. SYSTEM REQUIREMENTS**

### **1.1 Inspection**

1.1.1 Before installation, please inspect the pump carefully. If the pump appears to have sustained damage in transit, call your CheckPoint Authorized Distributor or CheckPoint Customer Service directly at +1 (504) 340-0770 to report and confirm damage. If it is determined that damage occurred in transit, a carrier claim will be required.

### **1.2 Storage**

The Series ATP pump has been thoroughly tested at the CheckPoint factory prior to shipment. This testing may leave residual fluids in the pump head. Although our pumps can be placed in service without environmental protection, we suggest that they are stored indoors until being commissioned.

### **1.3 Unpacking**

The ATP pump can be shipped as a single-head or dual-head pump. Please ensure that unpackaged pumps are securely placed in a safe area. Refer to the CheckPoint Quick Setup Guide for installation of the ATP pump.

### **1.4 Safety**

The Series ATP can produce high rod loads. All CheckPoint pump heads used with the ATP are designed to provide cover plates to minimize pinch points. Use of the ATP with another brand of pump head is not recommended and may present safety hazards.

### **1.5 Location**

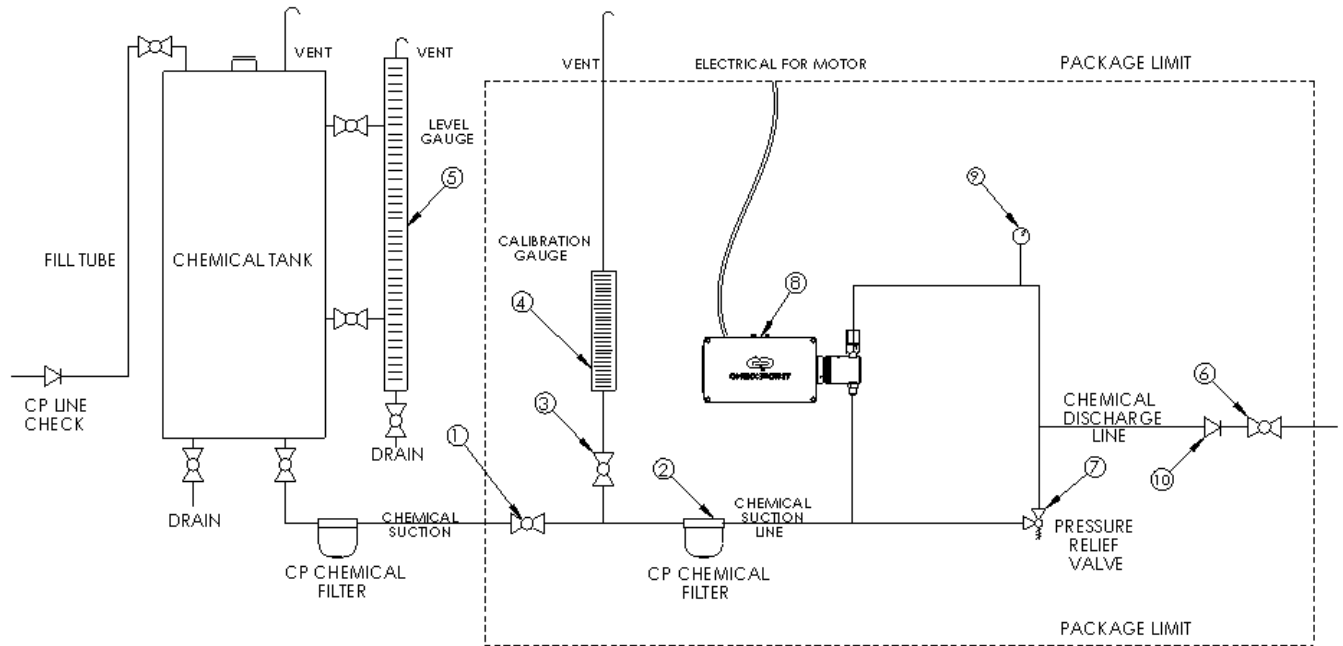
1.5.1 For safe and continuous operation, locate the pump with supplied base on a stable surface with sufficient access for the operator.

1.5.2 CheckPoint requires horizontal mounting for the Series ATP. Improper mounting could result in poor drive performance and difficulty during priming. The Series ATP base is provided to ensure proper orientation.

1.5.3 The pump may be mounted to a skid or other surface in a number of ways; however, clamping around the outside of the drive is not recommended. Proper mounting techniques increase accessibility during maintenance and troubleshooting.

## 1.6 Typical Installation Schematic

**FIGURE 1: TYPICAL INSTALLATION**



CheckPoint offers Series ATP pump packages, which contain all necessary components indicated within the Package Limit Line in Figure 1. CheckPoint can also supply pump packages that contain ALL components indicated in Figure 1, including the tank, mounted on a single skid, with or without full leak containment.

1. Suction Line Block Valve	4. CheckPoint Calibration Gauge*	7. PRV – Discharge Line	10. Discharge Check Valve*
2. CheckPoint Chemical Filter*	5. Tank Gauge	8. CheckPoint Series ATP Chemical Pump	
3. Calibration Gauge Block Valve	6. Discharge Line Block Valve	9. Discharge Pressure Gauge	

All items in Figure 1 can be purchased from CheckPoint. Call today for our latest prices on pumps, gauges, packages and other components.

\*CheckPoint OEM products

## 1.7 Connect chemical and process lines to checks

Always clean suction lines and check chemical containers to ensure that they are free of all foreign matter, sand, sludge, or chemical buildup.

**NOTE:** Even new chemical tanks can contain debris, which may cause system damage. Removing foreign debris from suction lines and chemical containers will substantially extend the life of the packing and other pump components.

**NOTE:** A presuction in-line chemical filter is strongly recommended to prevent early packing failure. Abrasive particles carried into the pump through suction plumbing is a common cause of packing failure. CheckPoint offers a range of chemical filters suitable for use with the Series ATP pump.

### 1.7.1 Suction Check

The attach point is a ¼" MNPT thread. Apply thread sealant, taking care to keep the sealant away from the suction inlet port. Sealant entering the check could cause the pump to operate incorrectly.

### 1.7.2 Discharge Check

The attach point is a ¼" FNPT thread. Apply thread sealant, taking care to keep the sealant away from the process line port. Sealant entering the process line could cause issues downstream.

## **2. MOTOR INSTALLATION**

The base model Series ATP comes with the motor already installed. Should you need to remove the motor for any reason, install per the motor install drawing located on the CP website.

Installation is made easier (though not required) using CheckPoint's installation tool, available for purchase (insert part # here).

### **2.1 Motor Requirements**

2.1.1 The Series ATP drive input accepts a male a 5/8" shaft.

- CheckPoint recommends a motor/gear reducer combination not exceeding 120 rpm at the ATP drive input shaft. The maximum-rated rotational speed of the ATP input shaft is 120 rpm. NEVER EXCEED 120 RPM.

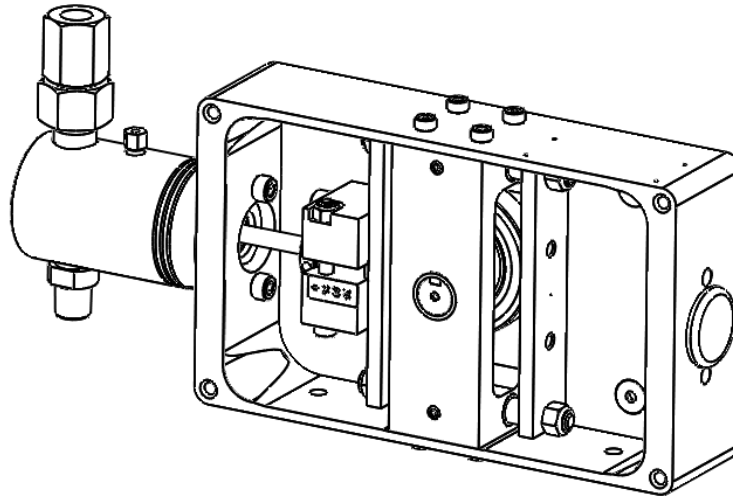
2.1.2 Connect Power

- Special attention should be paid to motor type and location hazards prior to hookup. The electric motor must be connected in accordance with all local regulations and area classifications and should include overload protection.
- It is recommended that the Series ATP installation is equipped with an easily accessible "emergency off" switch.

### **3. INJECTION HEAD ASSEMBLY**

The base-level Series ATP pump assembly comes with a single head attached to the drive assembly (shown in Figure 2).

**FIGURE 2: INJECTION HEAD ASSEMBLY**

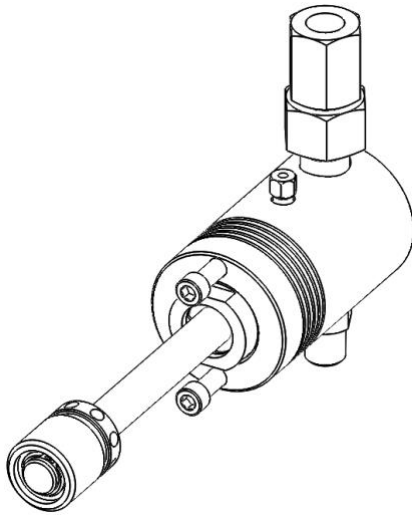


\*Motor and Base Removed for Clarity

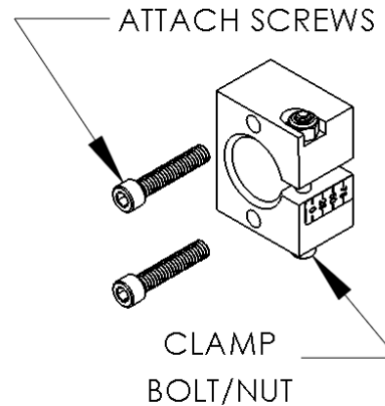
### 3.1 Adding an Injection Head.

The base model Series ATP comes with a single head but can be easily converted to a double-headed configuration. You will need the following assemblies:

**Figure 3: Head Assembly - Typical**

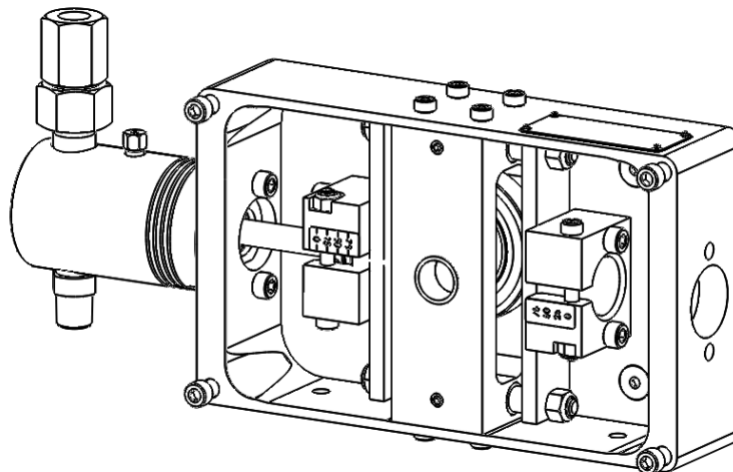


**Figure 4: Retainer Assembly – All Models**



3.1.1 Install the retainer assembly (clamp screw towards the front cover) to the carriage assembly using (2) attach screws.

**FIGURE 5: RETAINER ASSEMBLY AND CARRIAGE ASSEMBLY INSTALLATION**



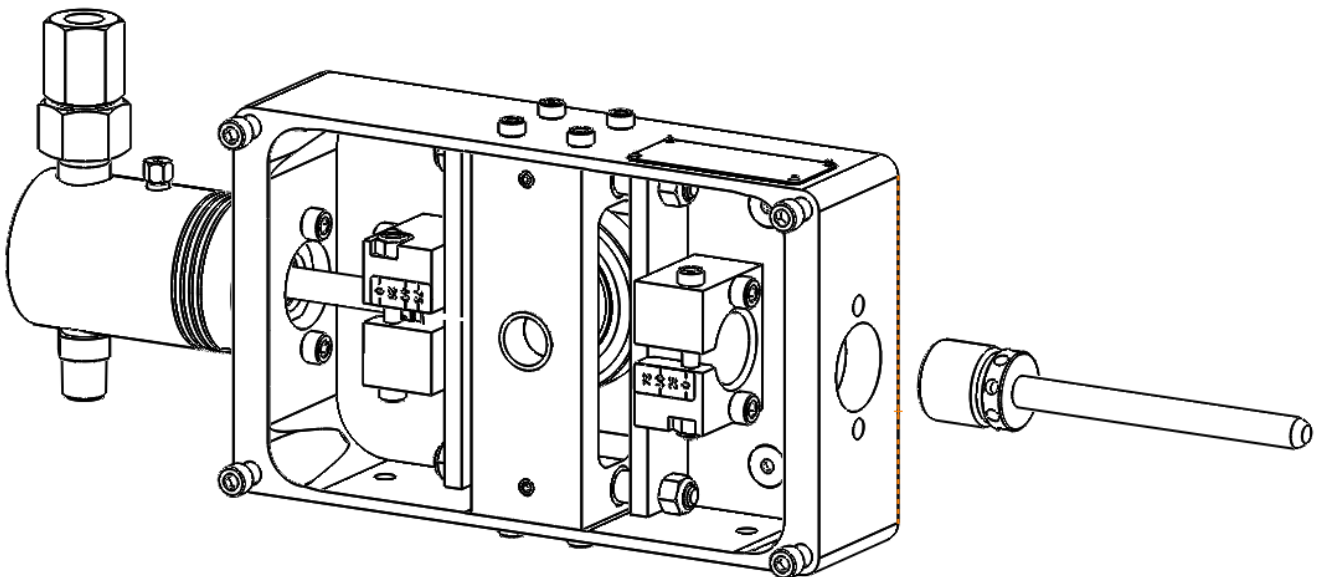
\*Motor and Base Removed for Clarity

3.1.2 Install plunger, snap ring, and screw assembly.

- Loosen the clamp screw approximately ½-turn.
- Screw the adjusting nut into the retainer assembly.

**NOTE:** The adjusting nut screwed in until it bottoms out on the end plate is full-stroke.

**FIGURE 6: PLUNGER, SNAP RING, AND SCREW ASSEMBLY INSTALLATION**

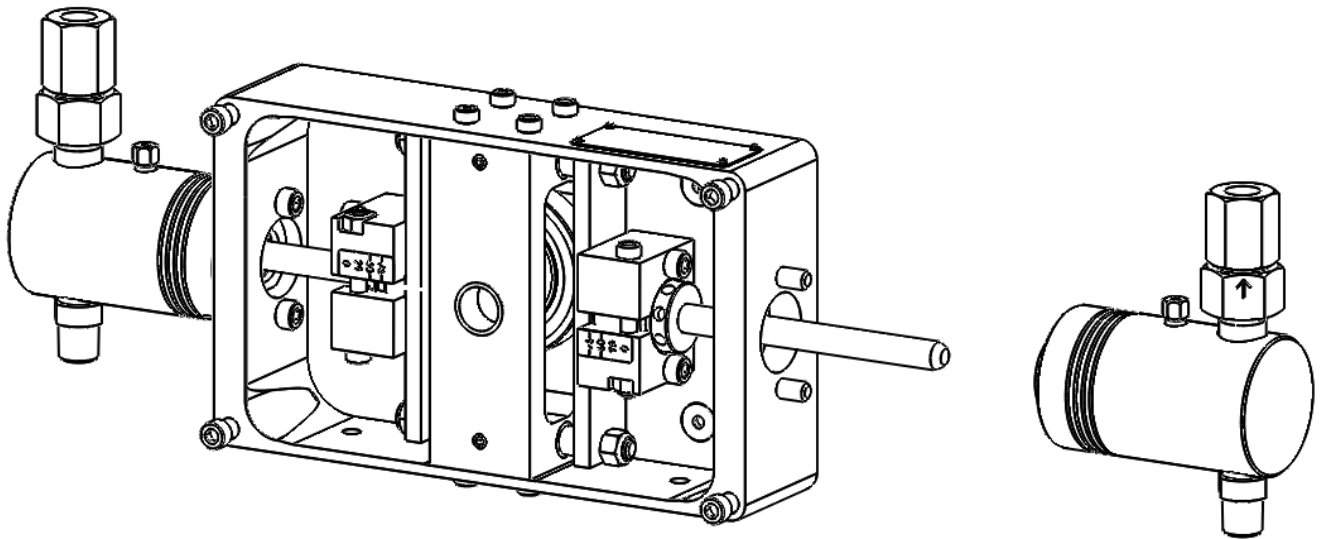




### 3.1.3 Attach head assembly

- Remove the two head bolts and install the thru drive housing wall.
- Add the approved grease on the tip of the plunger.
- Slide the head assembly over the plunger and tighten the head bolts to 20 in-lbs.

**FIGURE 7: HEAD ASSEMBLY ATTACHMENT**



## 4. STROKE LENGTH ADJUSTMENT

Both injection heads operate independently and have adjustable stroke lengths between 0" - 0.75".

### 4.1 Adjusting the stroke length

Pump Delivery Volume is controlled by adjusting the stroke length. To change the stroke length, the adjusting nut in the retainer assembly is screwed in or out depending upon the volume required. The retainer assembly block has indicators for approximate percentage of stroke.

**Max. stroke length (  $\frac{3}{4}$ " )** - Adjusting nut should be screwed in until it bottoms out on the end plate of the carriage. Do not over-tighten nut.

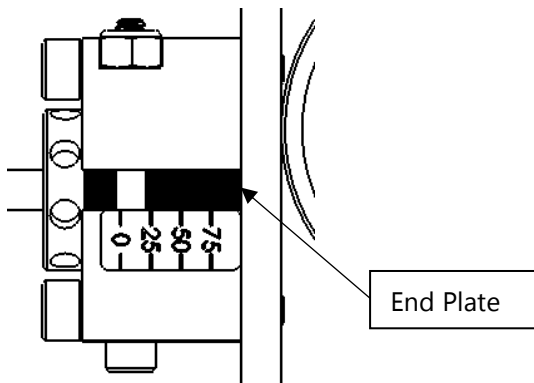
**Min. stroke length ( 0" )** - Adjusting nut should be unscrewed until the bottom of adjusting nut is at the 0% mark.

Adjust the stroke as directed below in Figures 8 and 9.

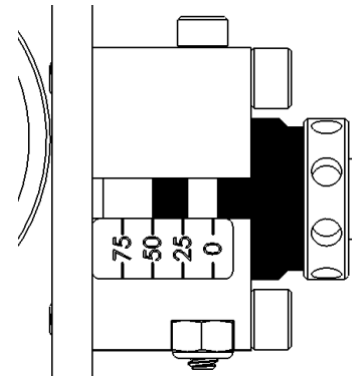
1. Turn off the drive system
2. Remove the front cover
3. Loosen the clamp screw ½-turn (or as required)
4. Insert the tool into the 3/16" adjusting nut hole
5. Rotate the adjusting nut to the desired stroke length (clockwise to increase stroke)
6. Restart the drive system
7. Check the flow rate
8. Once the desired flow is achieved, tighten the clamp screw.

**NOTE:** Very little clamping force is required to lock adjusting nut. Do not overtighten.

**FIGURE 8: SHOWN AT 100% STROKE**



**FIGURE 9: SHOWN AT 50% STROKE**



## **5. OPERATION**

The CheckPoint Series ATP drive requires no additional lubrication. The cam bearing is sealed, and the guide rods have sufficient grease in the carriage assembly prior to shipment.

### **Pump Flow Rate – DC Motor**

- The flow rate can be adjusted by changing the motor rpm and by changing the stroke length.

**NOTE:** Adjusting the motor's rpm during operation will not damage the Series ATP pump. Refer to your motor manufacturer's manual to determine the effects of adjusting RPM during operation.

### **Pump Flow Rate – AC Motor**

- The flow rate can be only adjusted by changing the stroke length.

## **5.1 Initial Startup**

- 5.1.1 Ensure that no leaks are visible prior to startup.
- 5.1.2 Disconnect the power to the motor.
- 5.1.3 Remove the outer cover to gain access to the plunger adjustment screw.

<p><b>NOTE:</b> The pump was tested in-house prior to shipping, using water with 5% water-based lubricant. If the residual liquid remaining in the pump from testing could cause issues with the chemical, flush the head prior to use.</p>
---

<p><b>WARNING:</b> PINCH POINTS EXIST INSIDE THE BOX. DISCONNECT POWER BEFORE REMOVING COVER.</p>
---

- 5.1.4 Open the chemical supply and system pressure valves.
- 5.1.5 Start the motor.
- 5.1.6 Bleed the injection head.
- 5.1.7 Adjust the flow rate.

## **6. TROUBLESHOOTING**

### **6.1 Pump does not stroke**

- 6.1.1 Check the power to the motor.
- 6.1.2 Ensure that the required amount of power is supplied to the motor and that the motor is turned on.
- 6.1.3 Check to see if the motor power is too low.
- 6.1.4 Ensure proper motor sizing for the particular application. Contact CheckPoint or your Authorized CheckPoint Distributor for sizing assistance.
- 6.1.5 Check to see if there is damage to the keyway.
- 6.1.6 A key may have sheared during an overload situation. Inspect all bores and keyways for damage or missing components.

### **6.2 Drive is excessively noisy**

- 6.2.1 Drive components may be worn.
- 6.2.2 The motor or gear reducer may be worn. Contact your drive component manufacturer.

### **6.3 Miscellaneous**

If you are experiencing an operating problem not listed above, or if none of the above troubleshooting actions solve your operating problem, please contact your Authorized CheckPoint Distributor, or contact CheckPoint directly at +1 (504) 340-0770 or [HELP@cppumps.com](mailto:HELP@cppumps.com). We will work to assist you in determining the appropriate next steps. Once CheckPoint has had the opportunity to assist you with troubleshooting your problem, please keep in mind the following information regarding repairs.

6.3.1 CheckPoint offers exchange programs to keep you in service.

6.3.2 CheckPoint will ship you a rebuilt pump, which you will be able to install prior to sending us your existing pump. Upon receipt of your pump, we will tear it down, rebuild it, and report to you our findings. We offer a fixed-price exchange plan, an actual-cost plan, and a consigned exchange plan. Please contact CheckPoint to learn more about our unique exchange services.

6.3.3 Although the Series ATP has been designed for easy operation and repair, the best way to ensure continued reliable service is to have your pump repaired by CheckPoint's factory. OEM repair services ensure CheckPoint quality and reliability.

6.3.4 After your CheckPoint pump has been repaired, it should perform like new

6.3.5 If your pump is anything less than exceptional, call us to determine what can be done to restore the pump to "like-new" performance.

6.3.6 Training sessions are available. CheckPoint strives to maintain excellence in all that we do, and we are happy to share our knowledge with you. If you would like to train your employees regarding anything involving CheckPoint Pumps & Systems, please contact us to discuss training options.