

CP CERTIFIED DIMENSIONAL DRAWING

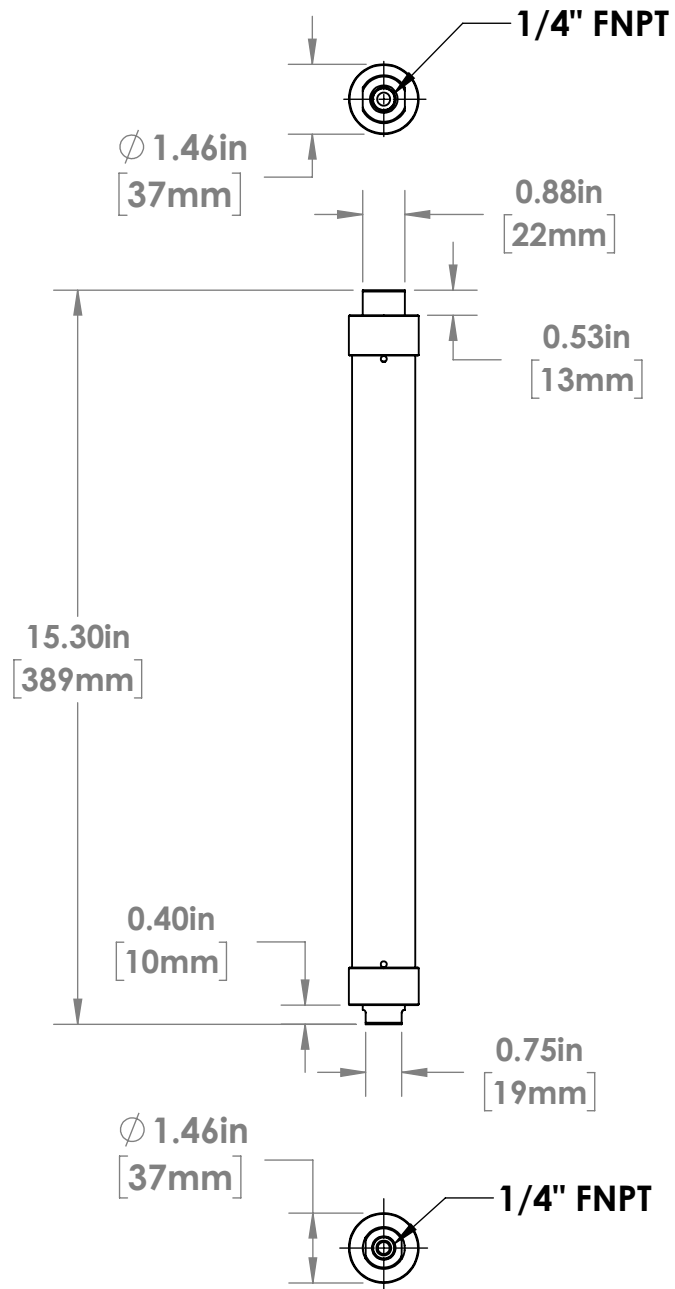

REVISIONS			
REV	DESCRIPTION	DATE	APPROVED
A	INITIAL RELEASE	4/6/2017	WRS

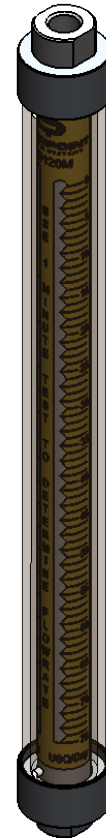

-- DO NOT SCALE DRAWING --

FOR REFERENCE ONLY
CONTROLLED BY PDM



21356 MARION LANE
MANDVILLE, LA 70471 USA
TEL 504.340.0770 -- FAX 888.217.6402

Checkpoint
Pumps & Systems

DWG. TITLE
**GS120M
CALIBRATION GAUGE**

REV. A	CDDGS120M	SIZE A
------------------	------------------	------------------

DRAWING NUMBER

SHEET 1 OF 1

PROPRIETARY AND CONFIDENTIAL

THE INFORMATION CONTAINED HEREIN IS PROPRIETARY TO CHECKPOINT SYSTEMS AND SHALL NOT BE REPRODUCED OR DISCLOSED IN WHOLE OR IN PART OR USED FOR ANY PURPOSE EXCEPT WHEN SUCH USER POSSESSES DIRECT WRITTEN AUTHORIZATION FROM CHECKPOINT SYSTEMS