

PUMP CUTAWAYS AND DRAWINGS

On the following pages are external and internal pump drawings with part numbers and material codes.
The following table identifies each material code.

MATERIAL CODES	
303 Stainless Steel	S3
304 Stainless Steel	S4
316 Stainless Steel	S6
17-4 PH Stainless Steel - HH 1150	S7
420 Stainless Steel	S0
6061 Aluminum	A6
Acetal	AC
Aflas®	AF
Buna-N®	BU
Ceramic - EverWear™	CE
Ceramic - NBD200™	CN
Delrin®	DL
Duplex 2205	D4
Super Duplex 2507	D5
Elgiloy®	EL
FKM	PF
FFKM	FK
Hastelloy® C276	HC
HNBR	HN
Iron	FE
Low carbon steel	ST
Monel®	MO
PVC	PV
PEEK	PK
Teflon® - Bronze Filled	TB
Teflon® - Carbon Filled	TC
Teflon® - Glass Filled	TG
Teflon® - Mica Filled	TM
Teflon® - Polyimide Filled	TP
Teflon® - Virgin	TF
Titanium	TI
Ultra High Molecular Weight Polyethylene (UHMWPE)	UH
Urethane	UR
Viton®	VI
XWL	XL

Call your CheckPoint representative
about pre-assembled rebuild kits.
+1 (504) 340-0770

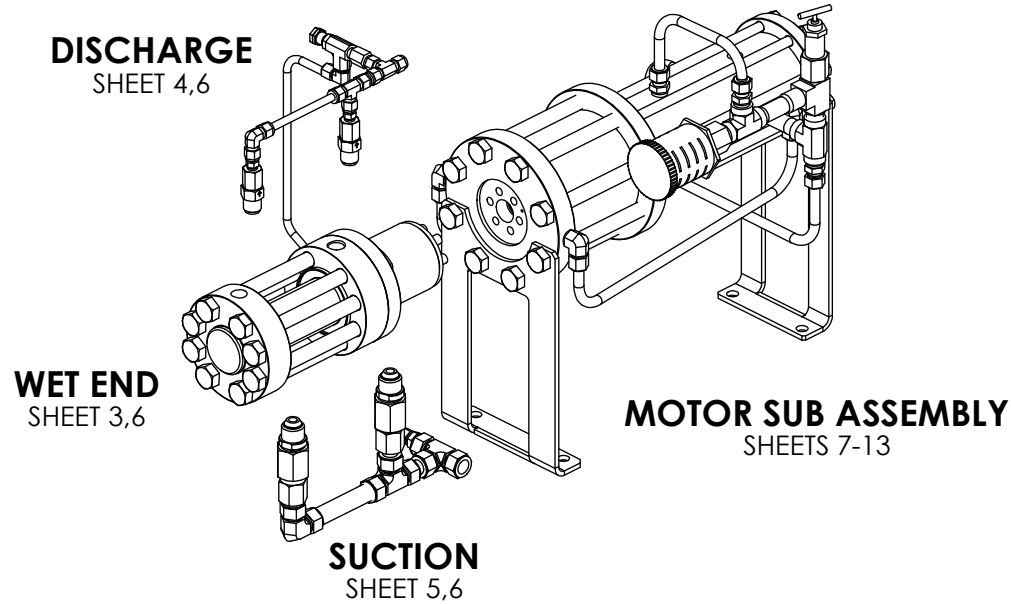

-- DO NOT SCALE DRAWING --

FOR REFERENCE ONLY
CONTROLLED BY PDM



CheckPoint
Pumps & Systems

DWG. TITLE
5412 PUMP ASSY - 3/4"
Double Acting - Ceramic

P5412CNQ3

SIZE
A

DRAWING NUMBER

PROPRIETARY AND CONFIDENTIAL

THE INFORMATION CONTAINED HEREIN IS PROPRIETARY TO CHECKPOINT SYSTEMS AND SHALL NOT BE REPRODUCED OR DISCLOSED IN WHOLE OR IN PART OR USED FOR ANY PURPOSE EXCEPT WHEN SUCH USER POSSESSES DIRECT WRITTEN AUTHORIZATION FROM CHECKPOINT SYSTEMS

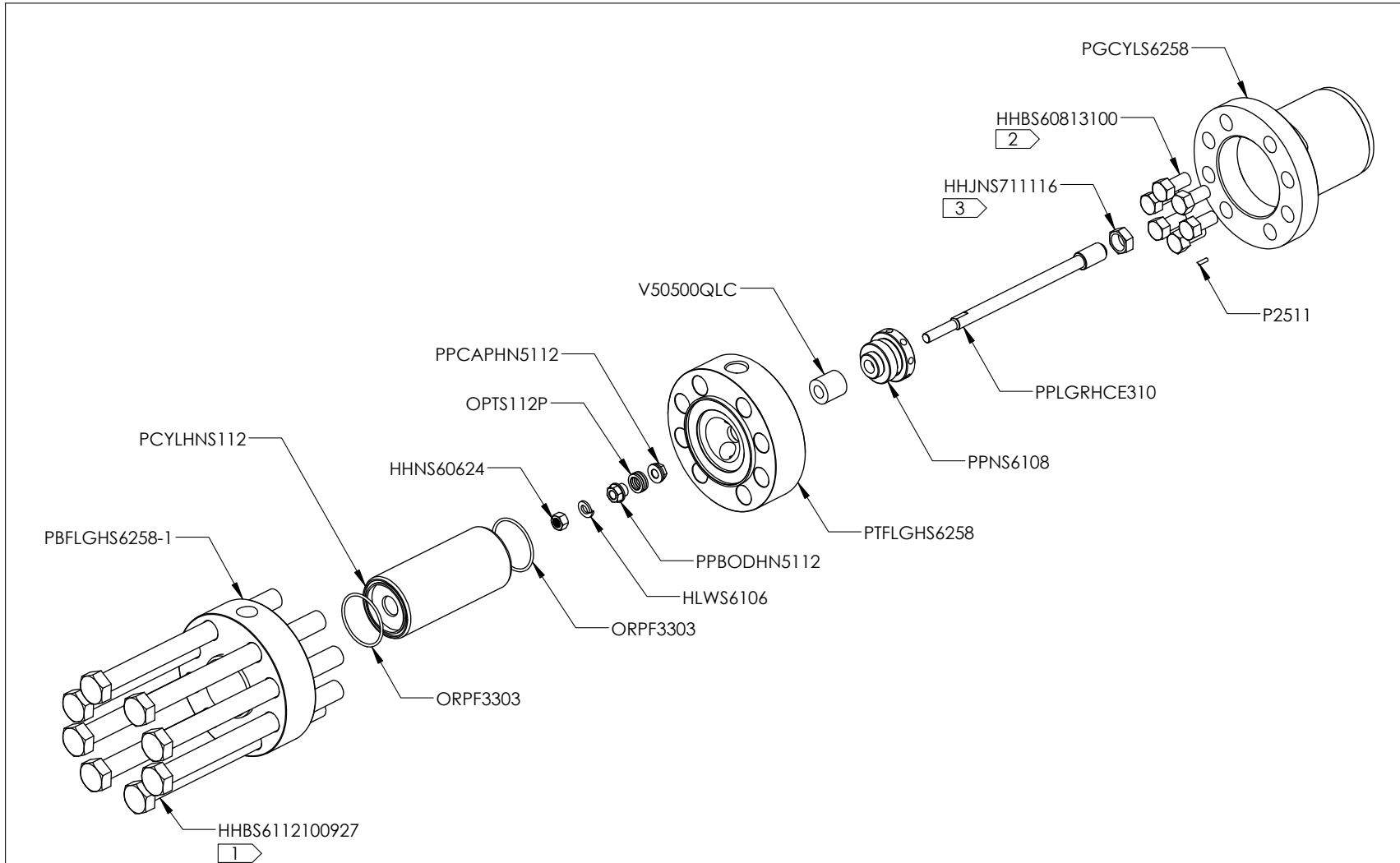

- 1 TORQUE BOLTS TO 220 ft-lbs
- 2 TORQUE BOLTS TO 60 ft-lbs
- 3 TORQUE NUT TO 41 ft-lbs

WET END

-- DO NOT SCALE DRAWING --

FOR REFERENCE ONLY CONTROLLED BY PDM		CheckPoint Pumps & Systems	
 <small>21356 MARION LANE MANDRILLE, LA 70471 USA TEL 504.340.0770 -- FAX 888.217.6402</small>		DWG. TITLE 5412 PUMP ASSY - 3/4" Double Acting - Ceramic	
		P5412CNQ3	
DRAWING NUMBER		SIZE A	

PROPRIETARY AND CONFIDENTIAL

THE INFORMATION CONTAINED HEREIN IS PROPRIETARY TO CHECKPOINT SYSTEMS AND SHALL NOT BE REPRODUCED OR DISCLOSED IN WHOLE OR IN PART OR USED FOR ANY PURPOSE EXCEPT WHEN SUCH USER POSSESSES DIRECT WRITTEN AUTHORIZATION FROM CHECKPOINT SYSTEMS

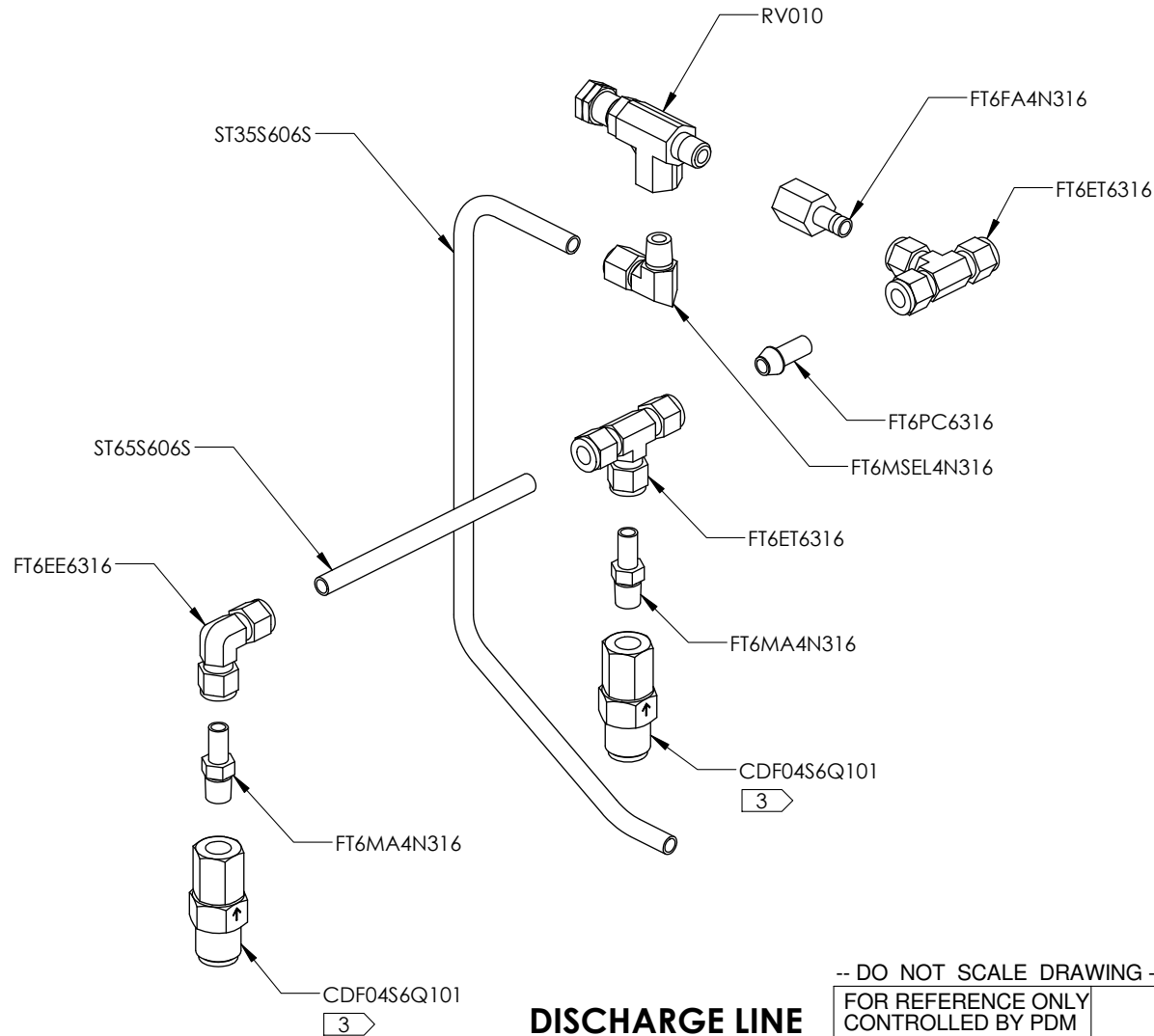

DISCHARGE LINE

3 TORQUE CHECK ASSY TO 200 ft-lbs

PROPRIETARY AND CONFIDENTIAL

THE INFORMATION CONTAINED HEREIN IS PROPRIETARY TO CHECKPOINT SYSTEMS AND SHALL NOT BE REPRODUCED OR DISCLOSED IN WHOLE OR IN PART OR USED FOR ANY PURPOSE EXCEPT WHEN SUCH USER POSSESSES DIRECT WRITTEN AUTHORIZATION FROM CHECKPOINT SYSTEMS

-- DO NOT SCALE DRAWING --

FOR REFERENCE ONLY
CONTROLLED BY PDM



CheckPoint
Pumps & Systems

DWG. TITLE
5412 PUMP ASSY - 3/4"
Double Acting - Ceramic

P5412CNQ3

DRAWING NUMBER

SIZE
A

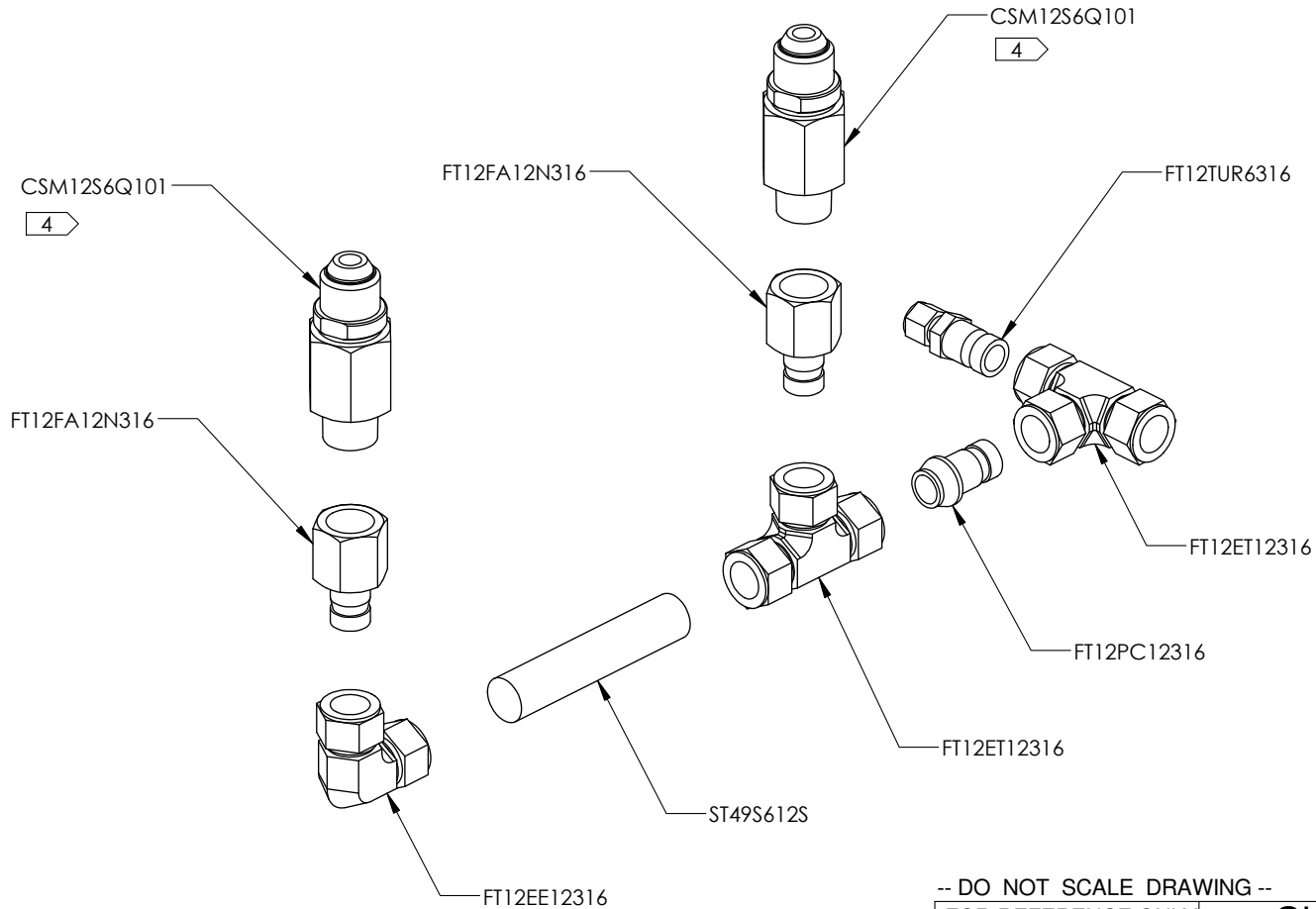

SUCTION LINE

4 TORQUE CHECK ASSY TO 200 ft-lbs

PROPRIETARY AND CONFIDENTIAL

THE INFORMATION CONTAINED HEREIN IS PROPRIETARY TO CHECKPOINT SYSTEMS AND SHALL NOT BE REPRODUCED OR DISCLOSED IN WHOLE OR IN PART OR USED FOR ANY PURPOSE EXCEPT WHEN SUCH USER POSSESSES DIRECT WRITTEN AUTHORIZATION FROM CHECKPOINT SYSTEMS

-- DO NOT SCALE DRAWING --

FOR REFERENCE ONLY
CONTROLLED BY PDM



CheckPoint
Pumps & Systems

DWG. TITLE
5412 PUMP ASSY - 3/4"
Double Acting - Ceramic

P5412CNQ3

SIZE
A

DRAWING NUMBER

Part Number	Description	QTY.	Mat. Codes	Temp Range
PGCYLS6258	GUARD CYLINDER	1	S6	NA
HHBS60813100	BOLT - GUARD CYLINDER	6	S6	NA
P2511	ALIGNMENT PIN	1	S0	NA
PTFLGHS6258	TOP FLANGE-HEAD	1	S6	NA
PCYLHNS112	CYLINDER HEAD	1	XL	NA
PPLGRHCE310	PLUNGER ROD	1	CE	NA
PPCAPHN5112	PISTON CAP	1	XL	NA
PPNS6108	PACKING NUT	1	S6	NA
PBFLGHS6258-1	BOTTOM FLANGE - HEAD	1	S6	NA
PPBODHN5112	PISTON BODY	1	XL	NA
CDF04S6Q101	DISCHARGE CHECK	2	S6/PF	NA
CSM12S6Q101	SUCTION CHECK	2	S6/PF	-29/204
V50500QLC	K58HRK112 PACKING	1	PF/TM/PK	-29/204, -268/288, -73/288
OPTS112P	OPTIRING	1	PF/PK/TC	-29/204, -73/288, -268/288
ORPF3303	O-RING	2	PF	-29/204
HLWS6106	K58HRK112 LOCK WASHER	1	S6	NA
HHJNS711116	JAM NUT	1	S7	NA
HHNS60624	JAM NUT	1	S6	NA
RV010	RELIEF VALVE	1	NA	NA
HHBS6112100927	BOLT - HEAD	8	S6	NA
FT6MA4N316	ADAPTER	2	S6	NA
FT6FA4N316	ADAPTER	1	S6	NA
FT6PC6316	PORT CONNECTOR	1	S6	NA
FT6ET6316	TEE	2	S6	NA
FT6EE6316	ELBOW	1	S6	NA
FT6MSEL4N316	ELBOW	1	S6	NA
ST35S606S	3/8" X 0.035 316SS TUBE	1	S6	NA
ST65S606S	3/8" X 0.065 316SS TUBE	1	S6	NA
ST49S612S	3/4" X 0.049 316SS TUBE	1	S6	NA
FT12PC12316	PORT CONNECTOR	1	S6	NA
FT12ET12316	TEE	2	S6	NA
FT12EE12316	ELBOW	1	S6	NA
FT12TUR6316	REDUCER	1	S6	NA
FT12FA12N316	ADAPTER	2	S6	NA

Call your CheckPoint representative about pre-assembled rebuild kits.
+1 (504) 340 0770
Head Rebuild Kit - K58HRK112

-- DO NOT SCALE DRAWING --

FOR REFERENCE ONLY CONTROLLED BY PDM		CheckPoint Pumps & Systems	
 <small>1356 MARION LANE MONROVIE, LA 70471 USA TEL 504.340.0770 -- FAX 888.217.6402</small>		DWG. TITLE 5412 PUMP ASSY - 3/4" Double Acting - Ceramic	
		P5412CNQ3	
DRAWING NUMBER		SIZE A	

PROPRIETARY AND CONFIDENTIAL

THE INFORMATION CONTAINED HEREIN IS PROPRIETARY TO CHECKPOINT SYSTEMS AND SHALL NOT BE REPRODUCED OR DISCLOSED IN WHOLE OR IN PART OR USED FOR ANY PURPOSE EXCEPT WHEN SUCH USER POSSESSES DIRECT WRITTEN AUTHORIZATION FROM CHECKPOINT SYSTEMS

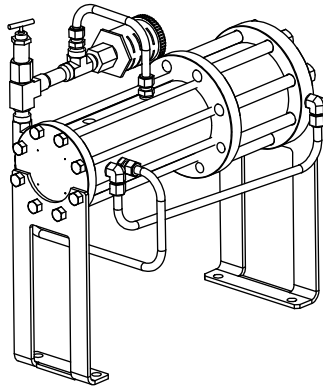

MOTOR ASSY

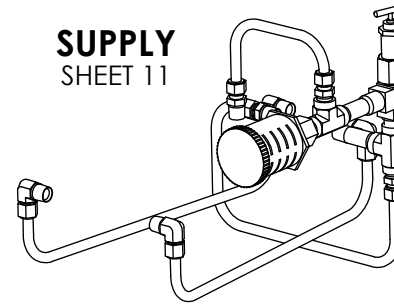

SUPPLY
SHEET 11

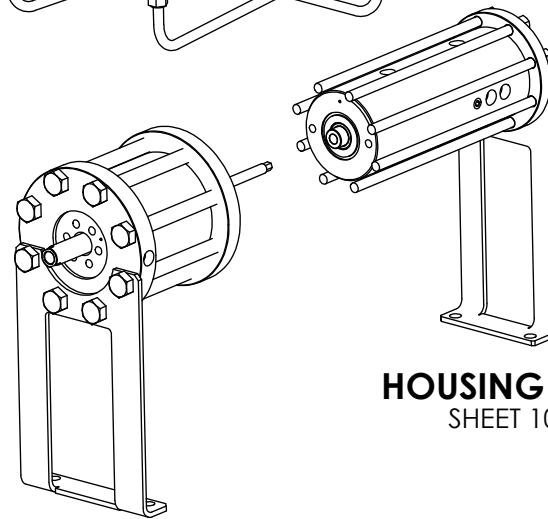

CYLINDER END
SHEET 9

HOUSING END
SHEET 10

-- DO NOT SCALE DRAWING --

FOR REFERENCE ONLY
CONTROLLED BY PDM



21356 MARION LANE
MANDRILLE, LA 70471 USA
TEL 504.340.0770 -- FAX 888.217.6402

CheckPoint
Pumps & Systems

DWG. TITLE
MOTOR SUB-ASSY 5400

P54MSA1

DRAWING NUMBER

SIZE
A

PROPRIETARY AND CONFIDENTIAL

THE INFORMATION CONTAINED HEREIN IS PROPRIETARY TO CHECKPOINT SYSTEMS AND SHALL NOT BE REPRODUCED OR DISCLOSED IN WHOLE OR IN PART OR USED FOR ANY PURPOSE EXCEPT WHEN SUCH USER POSSESSES DIRECT WRITTEN AUTHORIZATION FROM CHECKPOINT SYSTEMS

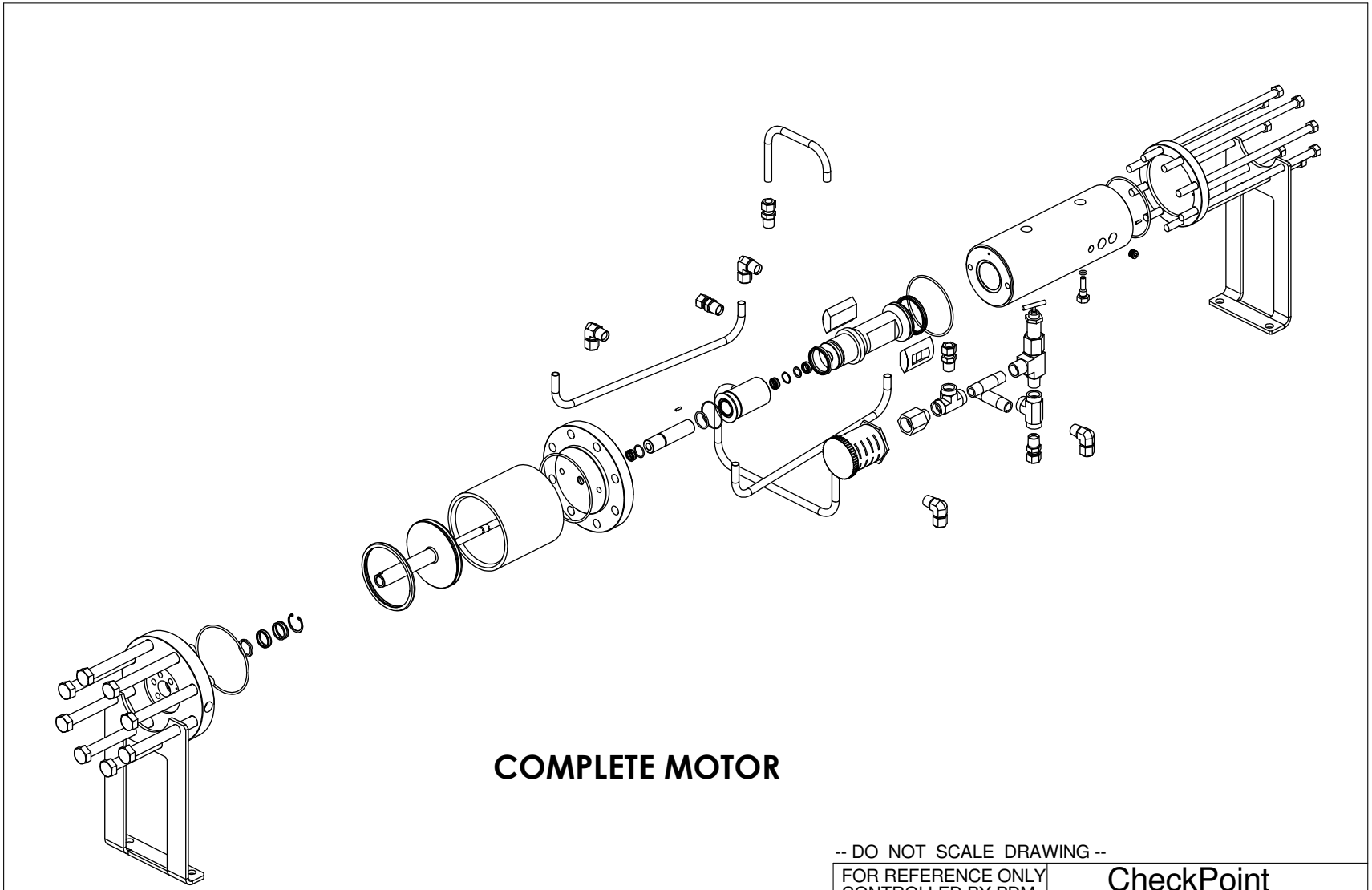

COMPLETE MOTOR

-- DO NOT SCALE DRAWING --

FOR REFERENCE ONLY
CONTROLLED BY PDM



CHECKPOINT
PUMPS & SYSTEMS
21356 MARION LANE
MANDRILLE, LA 70471 USA
TEL 504.340.0770 -- FAX 888.217.6402

CheckPoint Pumps & Systems	
DWG. TITLE MOTOR SUB-ASSY 5400	
P54MSA1	SIZE A
DRAWING NUMBER	

PROPRIETARY AND CONFIDENTIAL

THE INFORMATION CONTAINED HEREIN IS PROPRIETARY TO CHECKPOINT SYSTEMS AND SHALL NOT BE REPRODUCED OR DISCLOSED IN WHOLE OR IN PART OR USED FOR ANY PURPOSE EXCEPT WHEN SUCH USER POSSESSES DIRECT WRITTEN AUTHORIZATION FROM CHECKPOINT SYSTEMS

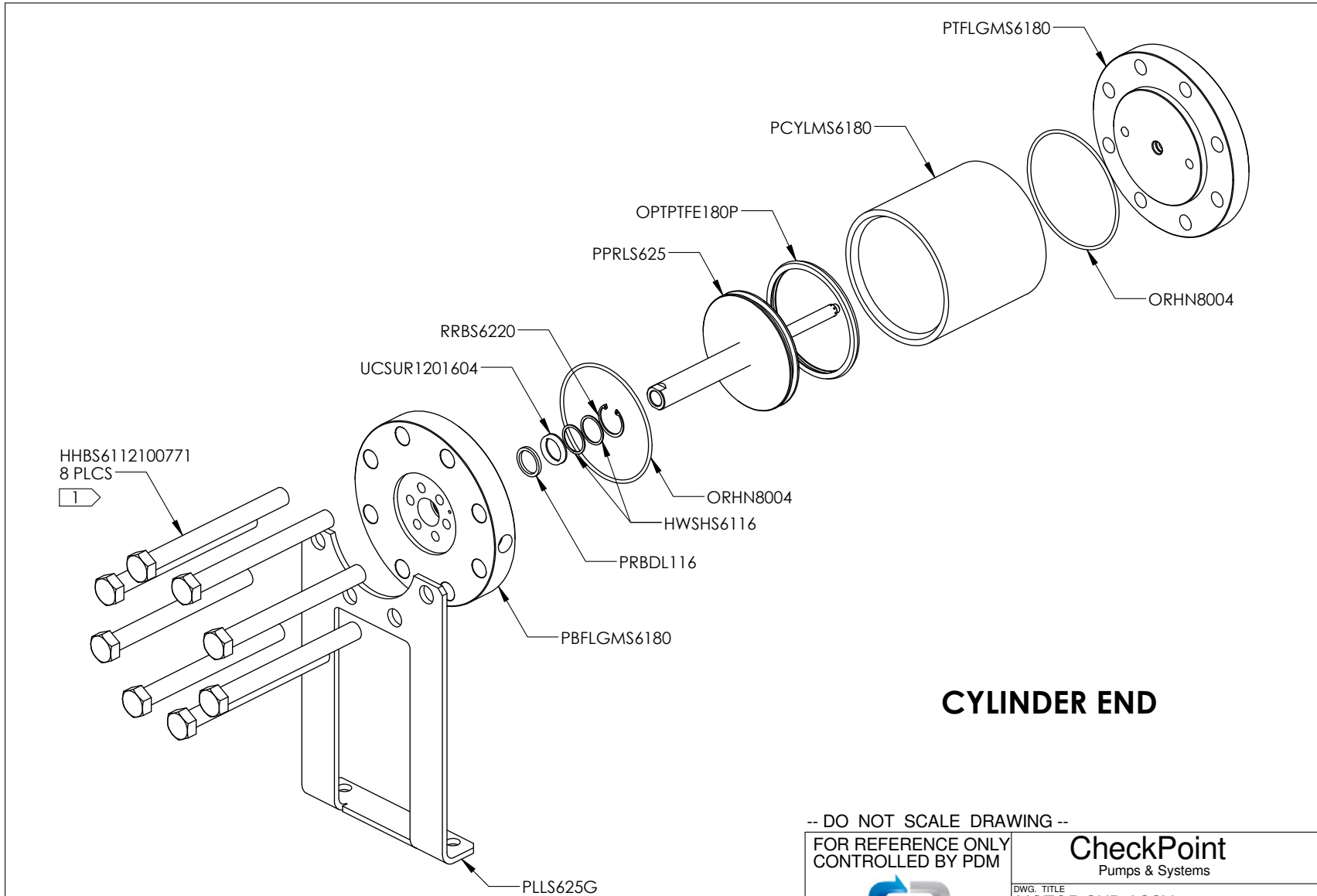

CYLINDER END

-- DO NOT SCALE DRAWING --

FOR REFERENCE ONLY
CONTROLLED BY PDM



21356 MARION LANE
MANDRILLE, LA 70471 USA
TEL 504.340.0770 -- FAX 888.217.6402

CheckPoint
Pumps & Systems

DWG. TITLE
MOTOR SUB-ASSY 5400

P54MSA1	SIZE A
DRAWING NUMBER	

1 TORQUE BOLTS TO 200 ft-lbs

PROPRIETARY AND CONFIDENTIAL

THE INFORMATION CONTAINED HEREIN IS PROPRIETARY TO CHECKPOINT SYSTEMS AND SHALL NOT BE REPRODUCED OR DISCLOSED IN WHOLE OR IN PART OR USED FOR ANY PURPOSE EXCEPT WHEN SUCH USER POSSESSES DIRECT WRITTEN AUTHORIZATION FROM CHECKPOINT SYSTEMS

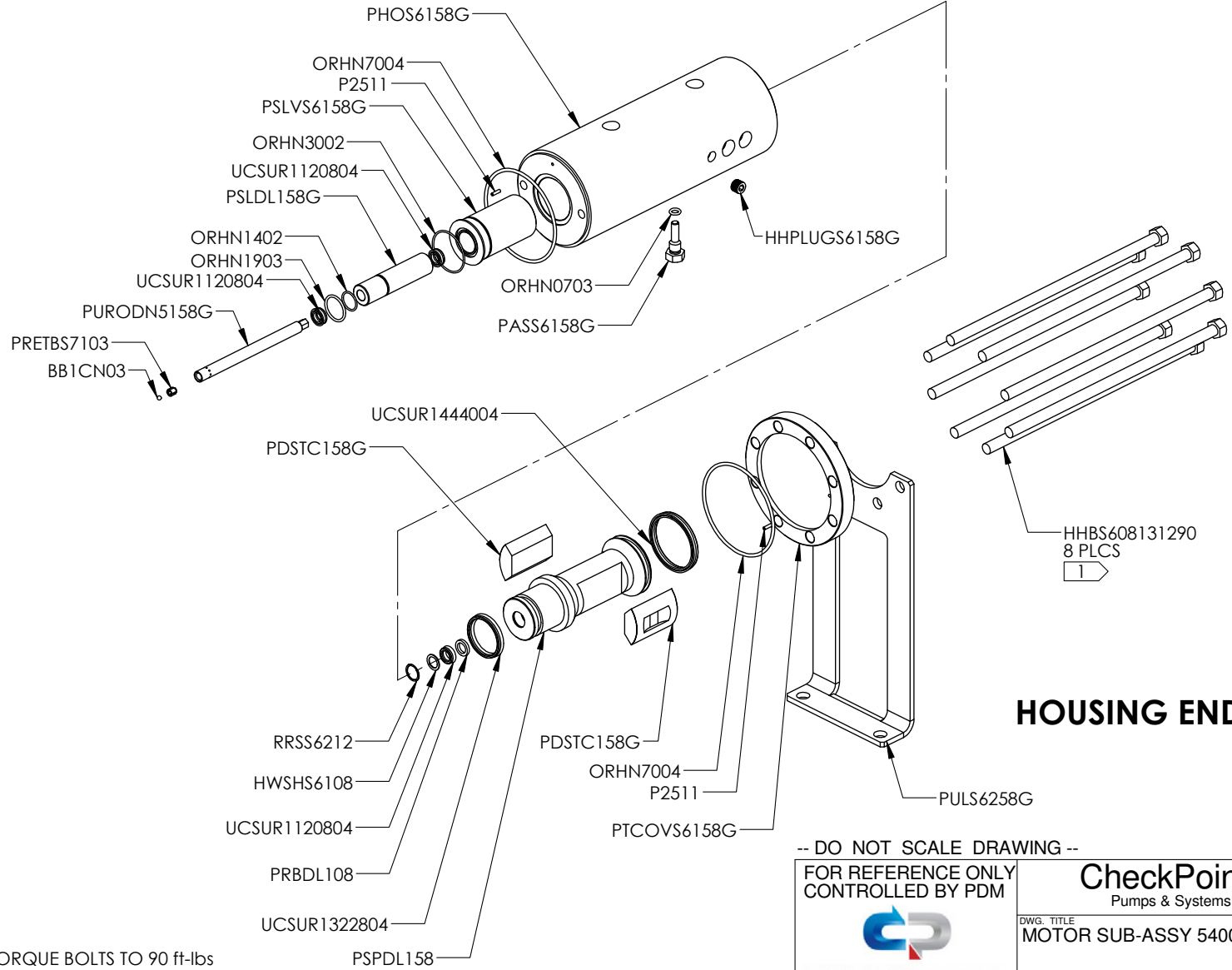

HOUSING END

-- DO NOT SCALE DRAWING --

FOR REFERENCE ONLY
CONTROLLED BY PDM



21356 MARION LANE
MANDRILLE, LA 70471 USA
TEL 504.340.0770 -- FAX 888.217.6402

CheckPoint Pumps & Systems	
DWG. TITLE MOTOR SUB-ASSY 5400	
P54MSA1	SIZE A
DRAWING NUMBER	

1 TORQUE BOLTS TO 90 ft-lbs

PROPRIETARY AND CONFIDENTIAL
 THE INFORMATION CONTAINED HEREIN IS PROPRIETARY TO CHECKPOINT SYSTEMS AND SHALL NOT BE REPRODUCED OR DISCLOSED IN WHOLE OR IN PART OR USED FOR ANY PURPOSE EXCEPT WHEN SUCH USER POSSESSES DIRECT WRITTEN AUTHORIZATION FROM CHECKPOINT SYSTEMS

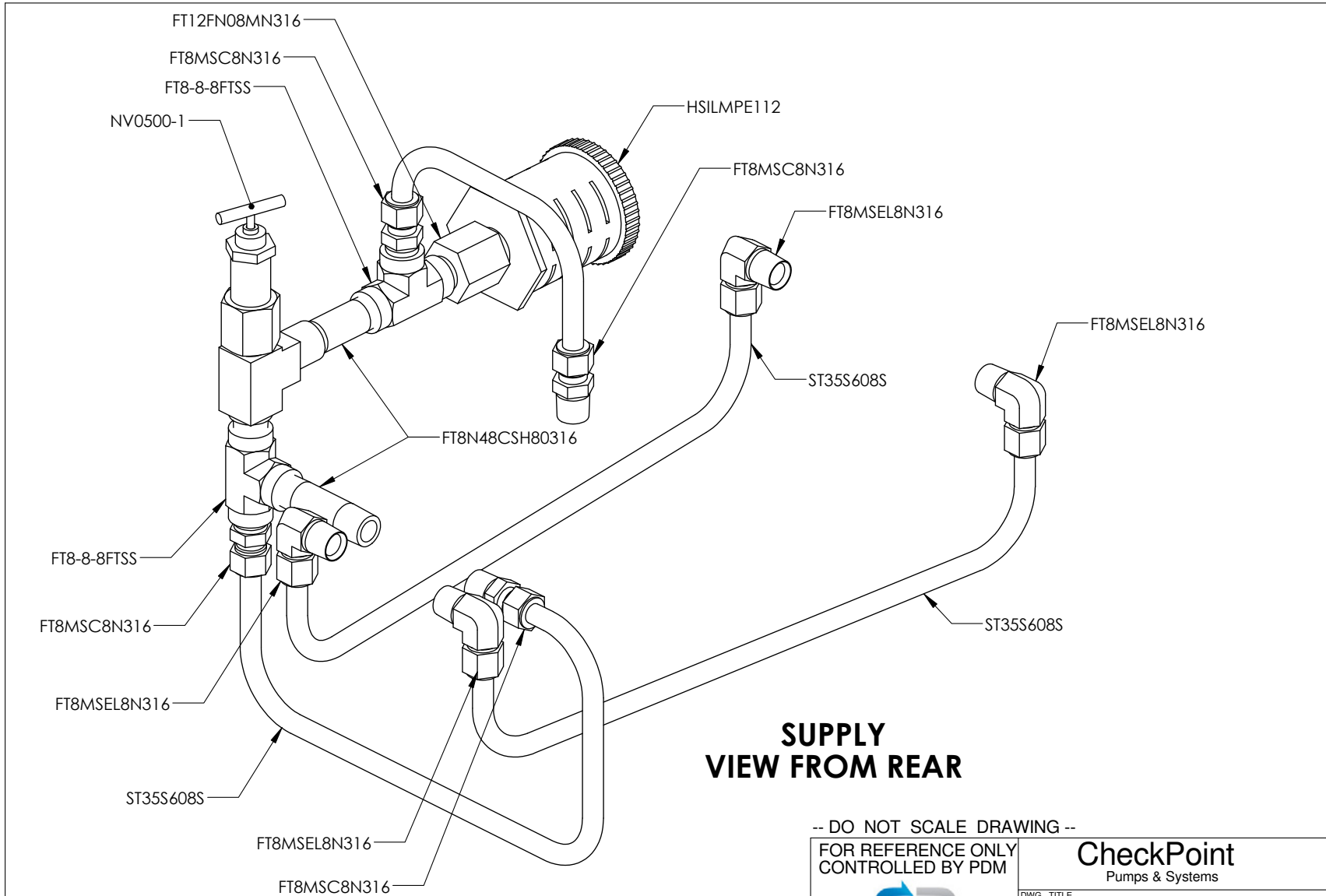

**SUPPLY
VIEW FROM REAR**

-- DO NOT SCALE DRAWING --

FOR REFERENCE ONLY CONTROLLED BY PDM		CheckPoint Pumps & Systems	
		DWG. TITLE MOTOR SUB-ASSY 5400	
<small>21356 MARION LANE MANDRILLE, LA 70471 USA TEL 504.340.0770 -- FAX 888.217.6402</small>		P54MSA1	SIZE A
DRAWING NUMBER		Page 11 of 17	

PROPRIETARY AND CONFIDENTIAL
THE INFORMATION CONTAINED HEREIN IS PROPRIETARY TO CHECKPOINT SYSTEMS AND SHALL NOT BE REPRODUCED OR DISCLOSED IN WHOLE OR IN PART OR USED FOR ANY PURPOSE EXCEPT WHEN SUCH USER POSSESSES DIRECT WRITTEN AUTHORIZATION FROM CHECKPOINT SYSTEMS

PART NUMBER	DESCRIPTION	QTY.	Mat. Codes	Temp. Range
NV0500-1	NEEDLE VALVE ASSEMBLY	1	S6	NA
PASS6158G	ALIGNMENT SCREW	1	S6	NA
PHOS6158G	HOUSING	1	S6	NA
P2511	ALIGNMENT PIN	2	S0	NA
PBFLGMS6180	BOTTOM FLANGE	1	S6	NA
PCYLS6180	CYLINDER MOTOR	1	S6	NA
PTCOVS6158G	TOP COVER	1	S6	NA
PSLVS6158G	SLEEVE	1	S6	NA
PSPDL158	SPOOL	1	DL	-40/121
PDSTC158G	D SLIDE	2	TC	-268/288
PSLDL158G	SPACER SLEEVE	1	DL	-40/120
PURODN5158G	UPPER ROD	1	XL	NA
PRETBS7103	RETAINER	1	S7	NA
BB1CN03	CERAMIC BALL	1	CN	NA
PPRLS625	PISTON ROD	1	S6	NA
HHBS608131290	BOLT	8	S6	NA
HHBS6112100771	BOLT	8	S6	NA
PTFLGMS6180	TOP FLANGE	1	S6	NA
PULS6258G	UPPER LEG	1	S6	NA
PLLS625G	LOWER LEG	1	S6	NA

PROPRIETARY AND CONFIDENTIAL

THE INFORMATION CONTAINED HEREIN IS PROPRIETARY TO CHECKPOINT SYSTEMS AND SHALL NOT BE REPRODUCED OR DISCLOSED IN WHOLE OR IN PART OR USED FOR ANY PURPOSE EXCEPT WHEN SUCH USER POSSESSES DIRECT WRITTEN AUTHORIZATION FROM CHECKPOINT SYSTEMS

-- DO NOT SCALE DRAWING --

FOR REFERENCE ONLY CONTROLLED BY PDM		CheckPoint Pumps & Systems	
 <small>21356 MARION LANE MANDOVILLE, LA 70471 USA TEL 504.340.0770 -- FAX 888.217.6402</small>		DWG. TITLE MOTOR SUB-ASSY 5400	
		P54MSA1	SIZE A
DRAWING NUMBER			

PART NUMBER	DESCRIPTION	QTY.	Mat. Codes	Temp. Range
UCSUR1444004	U-CUP SEAL	1	UR	-40/100
UCSUR1322804	U-CUP SEAL	1	UR	-40/100
UCSUR1201604	U-CUP SEAL	1	UR	-40/100
UCSUR1120804	U-CUP SEAL	3	UR	-40/100
OPTPTFE180P	PISTON SEAL	1	TM/AF	-268/288, 10/200
ORHN7004	O-RING	2	HN	-29/160
ORHN8004	O-RING	2	HN	-29/160
ORHN0703	O-RING	1	HN	-29/160
ORHN1903	O-RING	1	HN	-29/160
ORHN3002	O-RING	1	HN	-29/160
ORHN1402	O-RING	1	HN	-29/160
PRBDL116	BUSHING	1	DL	-40/121
PRBDL108	BUSHING	1	DL	-268/288
RRSS6212	SNAP RING	1	S6	NA
RRBS6220	SNAP RING	1	S6	NA
HWSHS6116	FLAT WASHER	2	S6	NA
HWSHS6108	FLAT WASHER	1	S6	NA
HSILMPE112	MUFFLER	1	NA	NA
HHPLUGS6158G	NPT PLUG	1	S6	NA
FT8MSEL8N316	ELBOW	4	S6	NA
FT8MSC8N316	CONNECTOR	4	S6	NA
FT8N48SCH80316	NIPPLE	2	S6	NA
FT8-8-8FT-SS	TEE	2	S6	NA
FT12FN08MN316	ADAPTER	1	S6	NA

K54MRU

Call your CheckPoint representative about pre-assembled rebuild kits. +1 (504) 340-0770
Motor Rebuild Kit - K54MRU - Contains all seals in the motor (air) end of the 5412 series pump.

-- DO NOT SCALE DRAWING --

FOR REFERENCE ONLY CONTROLLED BY PDM		CheckPoint Pumps & Systems	
		DWG. TITLE MOTOR SUB-ASSY 5400	
		P54MSA1	SIZE A
DRAWING NUMBER			

PROPRIETARY AND CONFIDENTIAL
 THE INFORMATION CONTAINED HEREIN IS PROPRIETARY TO CHECKPOINT SYSTEMS AND SHALL NOT BE REPRODUCED OR DISCLOSED IN WHOLE OR IN PART OR USED FOR ANY PURPOSE EXCEPT WHEN SUCH USER POSSESSES DIRECT WRITTEN AUTHORIZATION FROM CHECKPOINT SYSTEMS

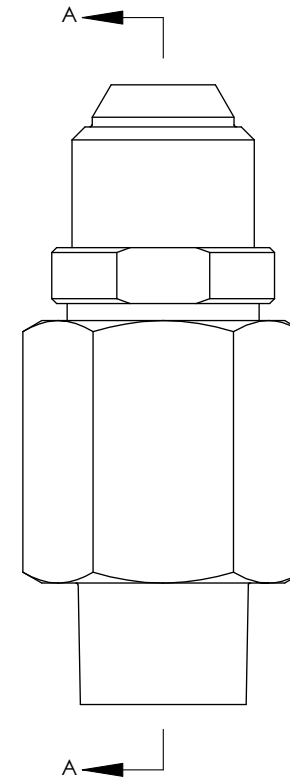
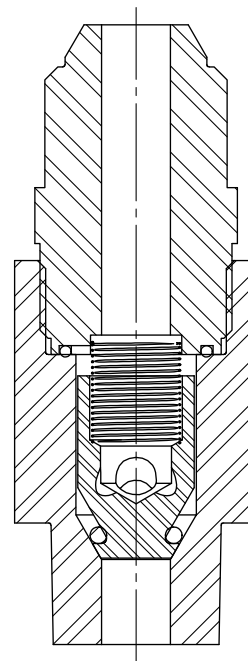
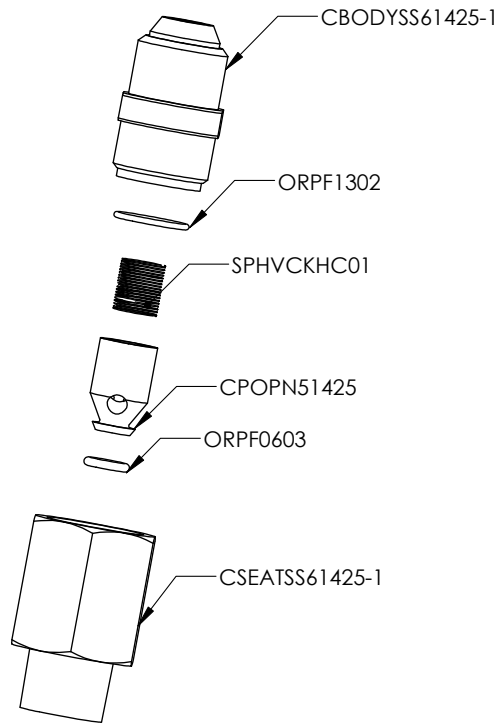

Call your CheckPoint representative about pre-assembled rebuild kits.
+1 (504) 340-0770
Check Valve Rebuild Kit - KFM12S6Q201

-- DO NOT SCALE DRAWING --

FOR REFERENCE ONLY
CONTROLLED BY PDM



CheckPoint
Pumps & Systems

DWG. TITLE
SUCTION CHECK ASSEMBLY

CSM12S6Q101

SIZE
A

DRAWING NUMBER

PART NUMBER	DESCRIPTION	QTY.	Mat. Codes	Temp. Range
CSEATSS61425-1	SEAT	1	S6	NA
CBODYSS61425-1	BODY	1	S6	NA
CPOPN51425	POPPET	1	XL	NA
SPHVCKHC01	SPRING	1	HC	NA
ORPF0603	O-RING	1	PF	-29/204
ORPF1302	O-RING	1	PF	-29/204

KFM12S6Q201

Call your CheckPoint representative about pre-assembled rebuild kits.
+1 (504) 340-0770
Check Valve Rebuild Kit - KFM12S6Q201- Contains both o-rings and spring

-- DO NOT SCALE DRAWING --

FOR REFERENCE ONLY CONTROLLED BY PDM		CheckPoint Pumps & Systems	
		DWG. TITLE SUCTION CHECK ASSEMBLY	
21356 MARION LANE MANDRVILLE, LA 70471 USA TEL 504.340.0770 -- FAX 888.217.6402		CSM12S6Q101	
DRAWING NUMBER		SIZE A	

PROPRIETARY AND CONFIDENTIAL

THE INFORMATION CONTAINED HEREIN IS PROPRIETARY TO CHECKPOINT SYSTEMS AND SHALL NOT BE REPRODUCED OR DISCLOSED IN WHOLE OR IN PART OR USED FOR ANY PURPOSE EXCEPT WHEN SUCH USER POSSESSES DIRECT WRITTEN AUTHORIZATION FROM CHECKPOINT SYSTEMS

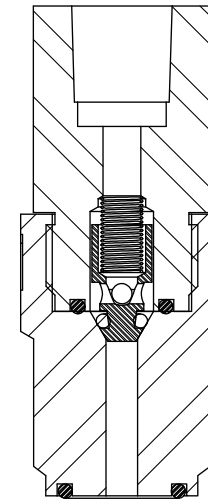
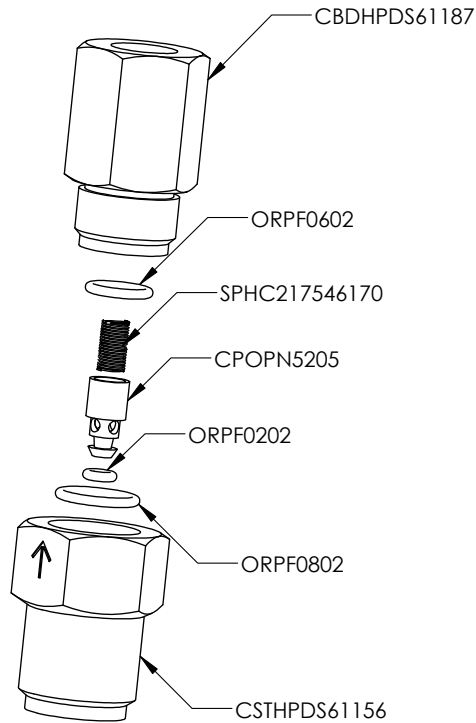

SECTION A-A

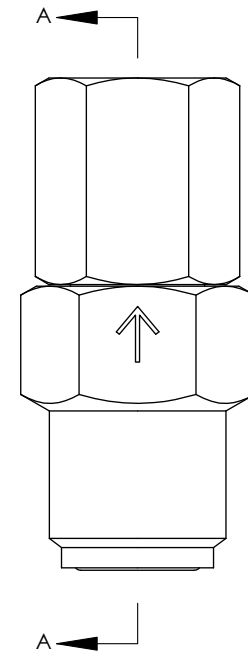

Call your CheckPoint representative about pre-assembled rebuild kits.
+1 (504) 340-0770
Check Valve Rebuild Kit - KFF04S6Q301

-- DO NOT SCALE DRAWING --

FOR REFERENCE ONLY
CONTROLLED BY PDM



CheckPoint
Pumps & Systems

DWG. TITLE
DISCHARGE CHECK ASSEMBLY

CDF04S6Q101

SIZE
A

DRAWING NUMBER

PROPRIETARY AND CONFIDENTIAL

THE INFORMATION CONTAINED HEREIN IS PROPRIETARY TO CHECKPOINT SYSTEMS AND SHALL NOT BE REPRODUCED OR DISCLOSED IN WHOLE OR IN PART OR USED FOR ANY PURPOSE EXCEPT WHEN SUCH USER POSSESSES DIRECT WRITTEN AUTHORIZATION FROM CHECKPOINT SYSTEMS

PART NUMBER	DESCRIPTION	QTY.	Mat. Codes	Temp. Range
CSTHPDS61156	SEAT	1	S6	NA
CBDHPDS61187	BODY	1	S6	NA
CPOPN5205	POPPET	1	XL	NA
SPHC217546170	SPRING	1	HC	NA
ORPF0602	O-RING	1	PF	-29/204
ORPF0802	O-RING	1	PF	-29/204
ORPF0202	O-RING	1	PF	-29/204

KFF04S6Q301

Call your CheckPoint representative about pre-assembled rebuild kits.
+1 (504) 340-0770
Check Valve Rebuild Kit - KFF04S6Q301- Contains o-rings and spring

-- DO NOT SCALE DRAWING --

FOR REFERENCE ONLY CONTROLLED BY PDM  <small>21356 MARION LANE MANDRVILLE, LA 70471 USA TEL 504.340.0770 -- FAX 888.217.6402</small>	CheckPoint Pumps & Systems	
	DWG. TITLE DISCHARGE CHECK ASSEMBLY	
CDF04S6Q101	SIZE A	
DRAWING NUMBER		

PROPRIETARY AND CONFIDENTIAL

THE INFORMATION CONTAINED HEREIN IS PROPRIETARY TO CHECKPOINT SYSTEMS AND SHALL NOT BE REPRODUCED OR DISCLOSED IN WHOLE OR IN PART OR USED FOR ANY PURPOSE EXCEPT WHEN SUCH USER POSSESSES DIRECT WRITTEN AUTHORIZATION FROM CHECKPOINT SYSTEMS